

Point Sconce

Installation Instructions

- ⚠ **CAUTION:**
Before starting, turn off power at main circuit panel.
- ⚠ **ADVERTENCIA:**
Antes de comenzar la instalacion, apague la corriente en tablero principal.
- ⚠ **ATTENTION:**
Coupez l'alimentation avant de proceder a l'installation.
- ⚠ **To prevent electrical hazards, this fixture must be installed by a licensed electrician.**

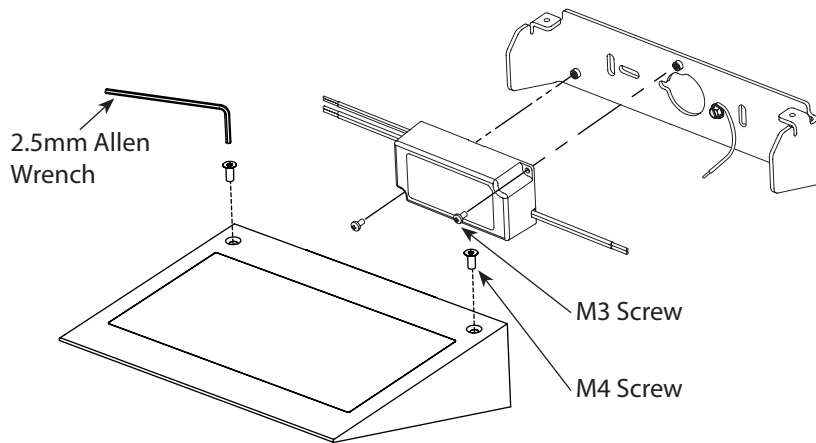

Step 1: Disassembly - Remove the bracket from the light unit.

- a. Use the included allen key to remove M4 screws and the bracket assembly.
- b. Use a philips head screwdriver to unscrew the M3 screws and remove the driver from the bracket.
- c. Disconnect the wires between the driver and the light by lifting the levers on the splice connector to release the wires.

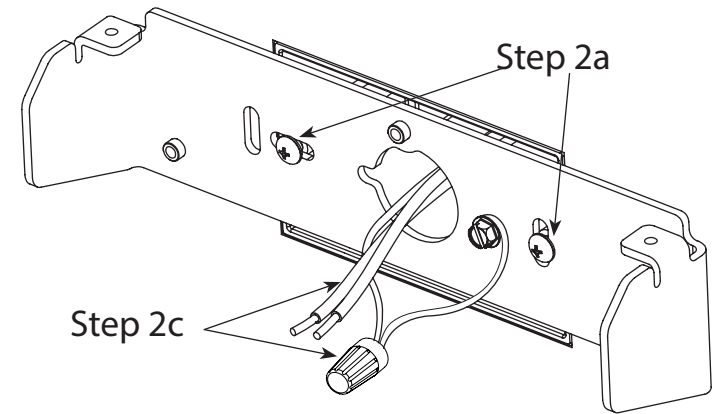
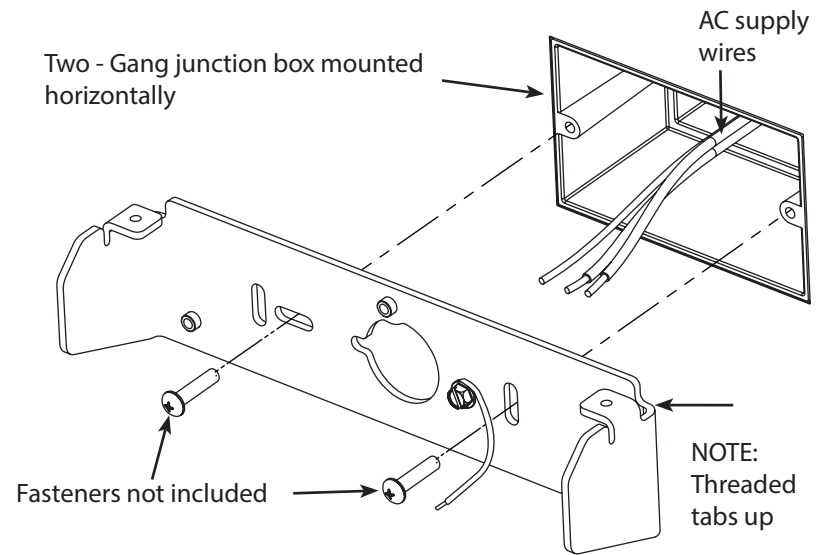

Step 2: Installation - LED Module Bracket Assembly

- a. Mount the bracket to the wall.
- b. Level the bracket with a spirit level
- c. Pull the supply wires through the bracket. Connect the yellow ground wire to the building ground wire.

Step 3: Installation - Driver Module

- Install Driver to Module Bracket with included M3 screws.
- Connect the driver's black lead to the supply hot wire. Connect the driver's white lead to the supply neutral wire.
- Select LED color temperature prior to installation.

Step 3a

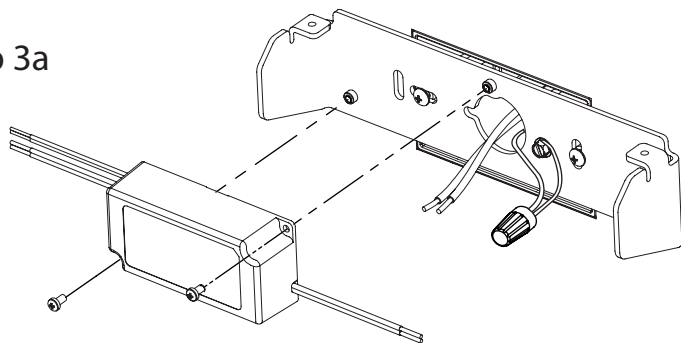

Step 3b

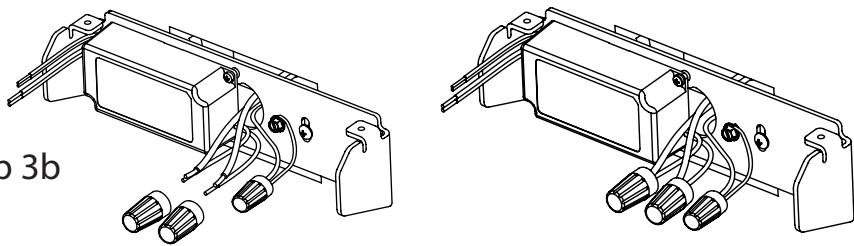

Step 3c

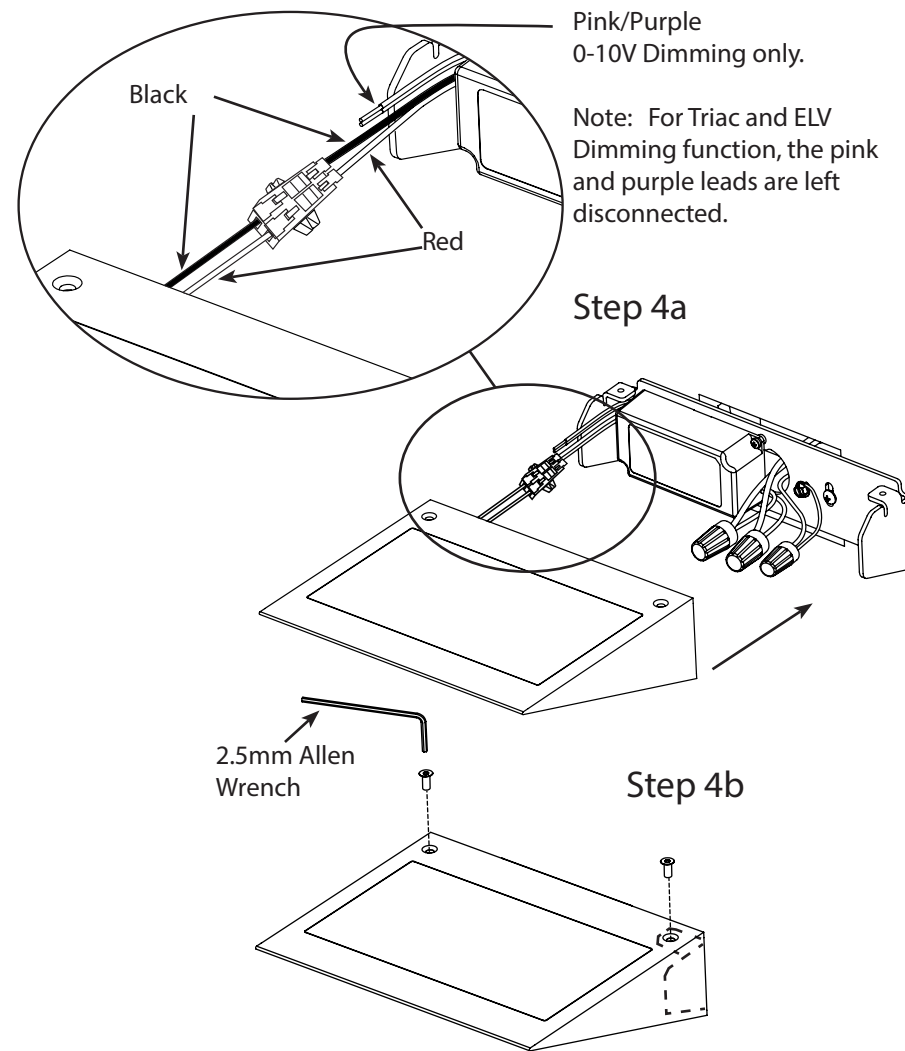
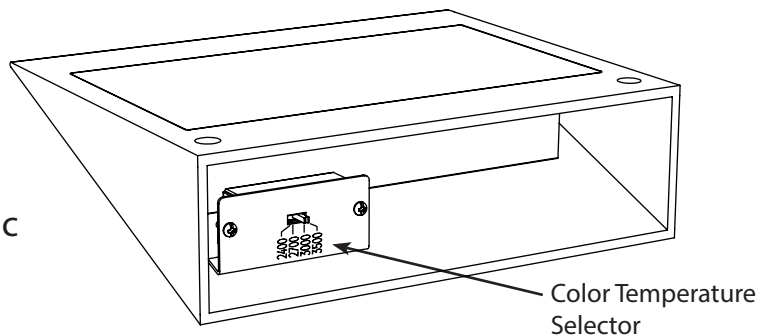

Step 4: Installation - Re-attach light unit to bracket and driver

- Connect the black wires together using the splice connector. Repeat the same for the red wires.
- Install LED assembly to Module bracket using included 2.5mm allen wrench.